

NAPOLEON[®]
FIREPLACES



Ascent X 36 shown with sandstone decorative brick panels

AVAILABLE NOW



ASCENT™ X 36

DIRECT VENT GAS FIREPLACE



For more information or to place an order call 1-800-461-5581 or visit napoleonfireplaces.com

Ascent™ X 36

Napoleon's Ascent X 36 enhances ambiance in any room with the most industry realistic, exclusive PHAZER® log set and glowing ember bed. The clean face design of the Ascent X 36 maximizes optimal viewing to ensure your new fireplace is enjoyed to the fullest. With a multitude of designer options the Ascent X 36 allows you to match your current home decor and can create a beautiful focus point in any room.

Product Features

- Exclusive PHAZER® log set and glowing ember bed are the most realistic in the industry
- Clean face design with no louvres
- Pan style burner
- Flex connector complete with shut off (Electronic ignition system only)
- Standard safety screen
- Millivolt or Electronic ignition systems available
- Optional MIRRO-FLAME™ Porcelain Reflective Radiant Panels
- Optional decorative panels (x3)
- Optional wrought iron decorative front
- Optional decorative front or 2" trim kit
- Optional remote control
- Optional blower kit



Wrought Iron Front
X36WI

Features/Options/Accessories



Heritage Decorative Front



Zen Decorative Front



2" Trim Kit



Decorative Brick Panels

Porcelain Reflective Radiant Panels, Herringbone, Sandstone and Newport



Convenient Remote Control



Napoleon®, leaders in design & technology have developed safety screens with aesthetically pleasing designs for every gas appliance to ensure ultimate safety and peace of mind for your family.

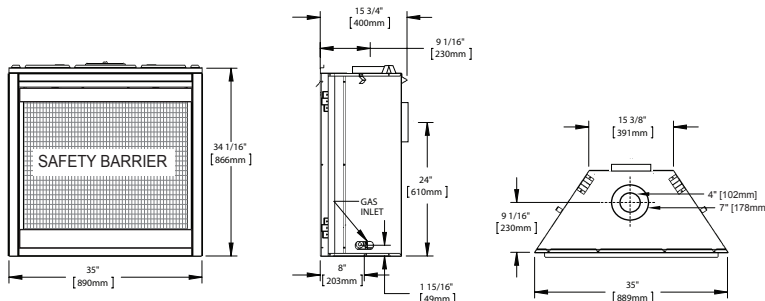

| Model | BTU'S (Input) | Top/Rear Venting | Height | | Front Width | | Depth | | Glass Size | | Efficiency |
|-------|---------------|------------------|----------|---------|-------------|---------|---------|---------|------------|-----------|------------|
| | | | Actual | Framing | Actual | Framing | Actual | Framing | Height | Width | |
| GX36 | 26,000 | 4" & 7" | 34 1/16" | 35" | 35" | 35 1/2" | 15 3/4" | 16" | 23 11/16" | 37 11/16" | 70.1% |

Certified under Canadian and American National Standards

Figures may vary with individual conditions such as floor plan layout, insulation value/heat loss of the house and geographical location.

Consult your owner's manual for complete installation instructions, accurate framing dimensions and proper clearances to combustible material. Check all local and national building codes and gas regulations. All specifications are subject to change without prior notice due to on-going product improvements. Products may not be exactly as shown. Napoleon® is a registered trademark of Wolf Steel Ltd. © Wolf Steel Ltd.



24 Napoleon Road, Barrie, Ontario, Canada L4M 0G8
103 Miller Drive, Crittenden, Kentucky, USA 41030
7200 Trans Canada Highway, Montreal, Quebec, Canada H4T 1A3
Tel: 705-721-1212 Fax: 705-722-6031
napoleonfireplaces.com



Authorized Dealer



Printed in Canada
02/2015